

1 1/16" BORE STAINLESS STEEL CYLINDER



SFR-17-□-□

Double Acting, Spring Bias



Mount: Stud
Type: Rotating Rod
Options: M, B, H, W, V, P6, P7, P8, S, N
Standard Stroke Lengths: 1/2", 1", 1-1/2", 2", 3", 4"
Spring Compressed: 7 lbs. **Spring At Rest:** 2 lbs.
Maximum Stroke: 26" For S option add 0.250

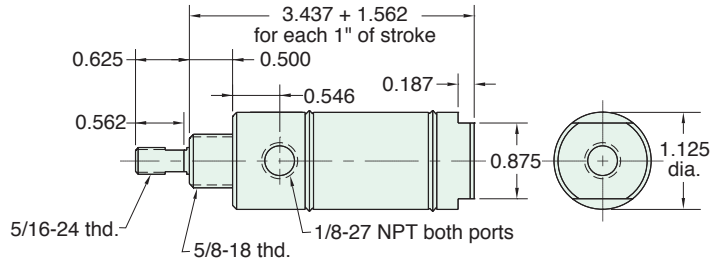

Nut included, but not shown on drawing

UBR-17-□-□

Double Acting, Rear Spring Bias



Mount: Universal
Type: Rotating Rod
Options: M, B, H, W, V, P2, P3, P4, P5, P6, P7, P8, N
Standard Stroke Lengths: 1/2", 1", 1-1/2", 2", 3", 4"
Spring Compressed: 7 lbs. **Spring At Rest:** 2 lbs.
Maximum Stroke: 16"

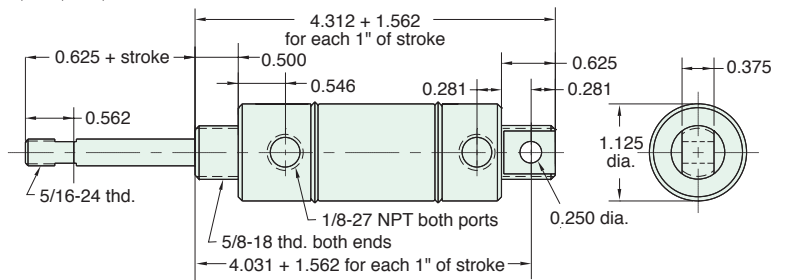

Furnished without nut(s). See Chart on [Page 34](#).

UFR-17-□-□

Double Acting Front Spring Bias



Mount: Universal
Type: Rotating Rod
Options: M, B, H, W, V, P2, P3, P4, P5, P6, P7, P8, N
Standard Stroke Lengths: 1/2", 1", 1-1/2", 2", 3", 4"
Spring Compressed: 7 lbs. **Spring At Rest:** 2 lbs.
Maximum Stroke: 26"

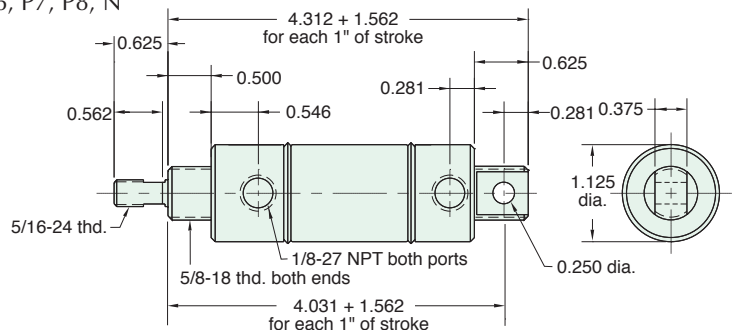

Furnished without nut(s). See Chart on [Page 34](#).